

Cybernet's Operator Control Unit (OCU) is intended for field-based control of unmanned robotic platforms. We have designed a controller that is compatible with the soldier's existing field uniform and equipment, incorporating advanced control technologies that offer more natural, intuitive, and effective interaction with the robot. The user interface is software-based, using pull-down menus and dynamic icons to offer maximum flexibility for controlling a range of robotic platforms.

**What's Included:**

The system consists of a handheld computer display and a wearable vest. The vest contains batteries and specialized electronics and networking components. During operation, the soldier holds the display and controls the platform using thumbpad input or touchscreen inputs. Data is sent and received from an unmanned platform over an IEEE 802.11b wireless link. Compressed video can be displayed using a hardware codec or via an ethernet tether.

**Special Features:**

The system has been designed to be highly modular and flexible. Any component can be replaced or upgraded as new technology becomes available. The system is JAUS compatible, and is based on the highly stable Linux operating system.





**Hardware:**

- 32-bit Transmeta Crusoe CPU (500mH3)
- 128 Mbytes RAM
- 128 Mbytes Flash/External CF Slot
- SVGA 800x600 16-bit color display
- 2 axis / 4 button joystick input
- NTSC video input
- 802.11b wireless communication
- H.263 Video Codec
- Ethernet Tether

**Weight:**

- Hand controller: 3 lbs, 3 oz.
- Vest: 6 lbs, 12 oz.

**Size:**

- Hand controller: width 11.9", height 6.0", depth 3.5"
- Vest: X-Large

**Software:**

- Linux based custom control software

**Current Features:**

- Light-weight custom GUI toolkit supports graphics, menus, status indicators overlaid on video proprietary network communication.

**Development Features:**

- Digital Elevation Map (DEM) data overlay
- Digital Line Graph (DLG) map overlay
- JAUS v3.0 Compliance
- Internal GPS/INS option

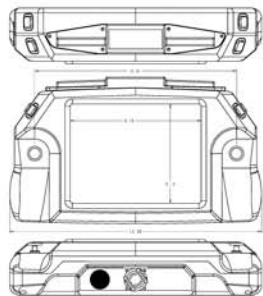
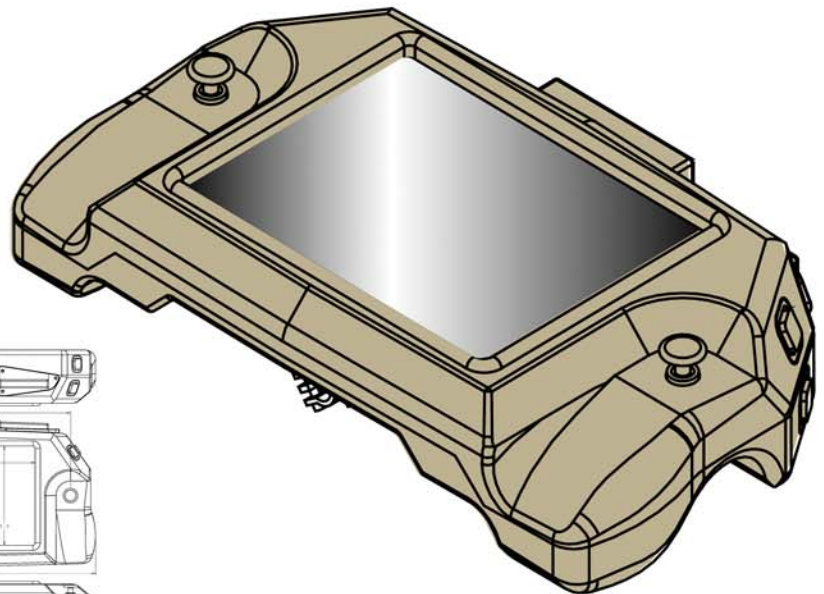

**Functionality:**

Currently the system allows tele-operated control of omni-directional platforms. We have an extensible user interface that allows for rapid prototyping of new user interfaces. The system is designed to detect functionality of a remote platform at connection and populate the user menus accordingly.

Software includes an SDK for interfacing to dual joysticks and buttons. We also have an SDK for viewing topographic maps and digital imagery of terrain.