

# F I R E F L Y

OPTICAL MOTION CAPTURE SYSTEM

The Firefly by Cybernet Systems Corporation is a high-speed real-time optical tracking system designed for full body motion capture. The system consists of a factory calibrated camera array that tracks the position of active tags. The tags are infrared light emitting diodes (LEDs) that are wired to a small controller that can be worn by the user. The controller itself does not need to be tethered to the camera array allowing the user to feel unencumbered and free. Each tag controller is capable of hosting up to 32 tags, and multiple controllers can be slaved to handle up to 256 tags. Synchronization between the tag controllers and camera arrays is accomplished using proprietary optical synchronization techniques.

The Firefly system uses line scan camera technology to track the tags accurately and quickly. With a scan rate of 900 tags per second, a user tracked body with 30 tags can be tracked at a rate of 30 scans per second. When fewer tags are tracked, the scan rate can be increased (e.g. 10 tags at a rate of 90 Hz.) Since this motion capture system is optical, it retains its accuracy when operating near metal objects and structures or noisy machinery. The system was developed to operate in ordinary office, studio and laboratory settings without having to observe special lighting precautions.

The factory calibrated Firefly system is quick and easy to set up, providing the accuracy of an optical system with the real-time speed of other tracking technologies at a reasonable cost. High speed data processing yields 3D motion data not only in real time (no post processing required!) but with only a few milliseconds delay. This makes the Firefly system ideal for an in-house motion capture capability for any game developer, animator, virtual reality environment creator, or researcher.

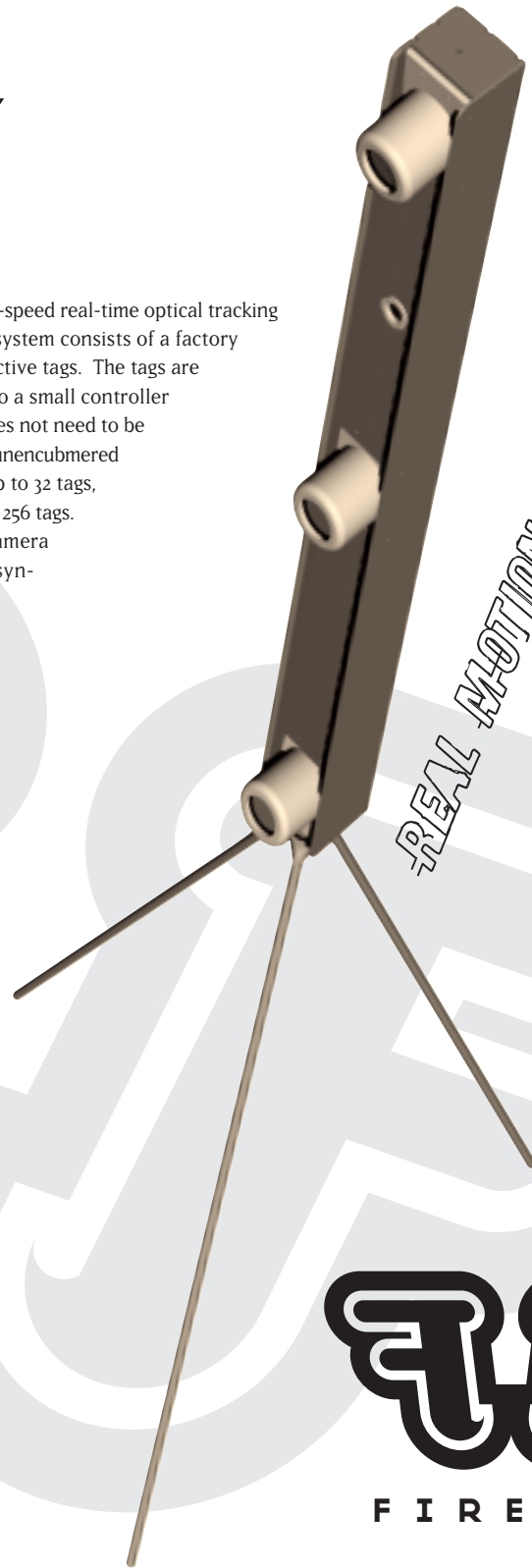

*REAL MOTION - REAL TIME*



F I R E F L Y

**F I R E F L Y**  
OPTICAL MOTION CAPTURE SYSTEM

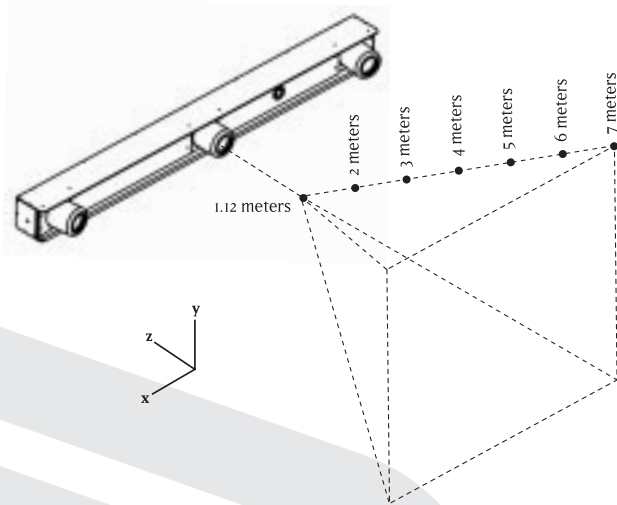

**Field Of Vision at:**

- 2 meters** - 0.90m H x 1.44m V
- 3 meters** - 1.90m H x 2.18m V
- 4 meters** - 2.86m H x 2.92m V
- 5 meters** - 3.61m H x 3.63m V
- 6 meters** - 4.08m H x 4.37m V
- 7 meters** - 4.53m H x 5.08m V

**FIREFLY PROTOYPE SPECIFICATIONS**

**Camera Array Dimensions:** 4 in (H) x 6 in (D) x 50 in (L)

**Camera Array Weight:** 22.3 pounds

**Power Requirements:** 110/120 VAC @ 60 Hz (220/240 VAC @ 50 Hz optional)

**Infrared Tag Dimensions:** 0.50 in x 0.38 in x 0.38 in

**Tag Weight:** 0.01 ounces (approx.)

**Tag Controller Dimensions:** 5.5 in x 5.5 in x 1.5 in

**Tag Controller Weight:** 14.7 ounces (with batteries)

**Tag Controller Power:** 2 AA alkaline batteries

**Maximum Sampling Rate:** 900 tags per second (e.g. 30 Hz with 30 tags, 60 Hz with 15 tags)

**Field of View:** 40 degrees x 40 degrees

**System Range:** 7 meters minimum

**Measurement Latency:** 3 milliseconds

**RMS Accuracy:**

Distance from Sensor	2 meter	4 meters	6 meters
Field of View	0.90 m x 1.44 m	2.86 m x 2.92 m	4.08 m x 4.37
X and Y accuracy	0.7 mm	1.4 mm	2.1 mm
Z accuracy	1.0 mm	2.0 mm	3.0 mm

**Interface:** 115.2Kbaud RS-232 Serial Port

**System Options:** Digitizing Probe for 3D digitizing applications

High-speed Ethernet interfaces

**Supplied Software:** Windows NT/95 capture, display, and data conversion application

Windows 95/NT & UNIX APIs for custom applications

